



GENERAL DESCRIPTION



The ICS81006 is a high performance, low jitter/low phase noise VCXO and is a member of the HiPerClockS™ family of high performance clock solutions from ICS. The ICS81006 works in conjunction with a pullable crystal to generate an output clock over the range of 12MHz - 40MHz and has 6 LVCMOS outputs, effectively integrating a fanout buffer function.

The frequency of the VCXO is adjusted by the VC control voltage input. The output range is $\pm 100\text{ppm}$ around the nominal crystal frequency. The VC control voltage range is $0 - V_{DD}$. The device is packaged in a small 4mm x 4mm VFQFN package and is ideal for use on space constrained boards typically encountered in ADSL/VDSL applications.

FEATURES

- Six LVCMOS/LVTTL outputs, 20 Ω nominal output impedance
- Output Q5 can be selected for $\div 1$ or $\div 2$ frequency relative to the crystal frequency
- Output frequency range: 12MHz to 40MHz
- Crystal pull range: $\pm 90\text{ppm}$ (typical)
- Synchronous output enable places outputs in High-Z state
- On-chip filter on VIN to suppress noise modulation of VCXO
- V_{DD}/V_{DDO} combinations
 - 3.3V/3.3V
 - 3.3V/2.5V
 - 3.3V/1.8V
 - 2.5V/2.5V
 - 2.5V/1.8V
- 4mm x 4mm 20 Lead VFQFN package is ideal for space constrained designs
- 0°C to 70°C ambient operating temperature
- Available in both standard and lead-free RoHS compliant packages

BLOCK DIAGRAM

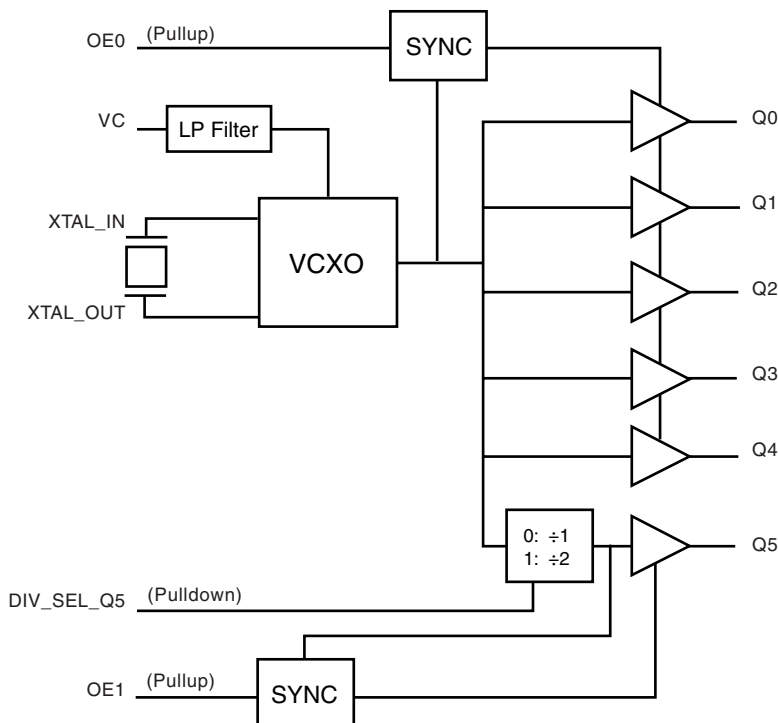

PIN ASSIGNMENT

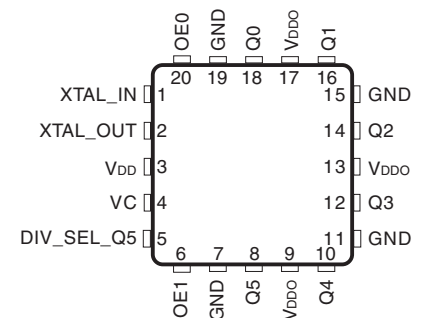

ICS81006

20-Lead VFQFN

4mm x 4mm x 0.95 package body

K Package

Top View



TABLE 1. PIN DESCRIPTIONS

Number	Name	Type		Description
1, 2	XTAL_IN, XTAL_OUT	Input		Crystal oscillator interface. XTAL_IN is the input. XTAL_OUT is the output.
3	V _{DD}	Power		Core supply pin.
4	VC	Input		Control voltage input.
5	DIV_SEL_Q5	Input	Pulldown	Output divider select pin for Q5 output. When LOW, ÷1. When HIGH, ÷2, LVCMOS/LVTTL interface levels.
6	OE1	Input	Pullup	Output enable pin. When HIGH, Q5 output is enabled. When LOW, forces Q5 to HiZ state. LVCMOS/LVTTL interface levels.
7, 11, 15, 19	GND	Power		Power supply ground.
8, 10, 12, 14, 16, 18	Q5, Q4, Q3, Q2, Q1, Q0	Output		Single-ended clock outputs. LVCMOS/LVTTL interface levels. 15Ω typical output impedance.
9, 13, 17	V _{DDO}	Power		Output supply pins.
20	OE0	Input	Pullup	Output enable pin. When HIGH, Q0:Q4 outputs are enabled. When LOW, forces Q0:Q4 to HiZ state. LVCMOS/LVTTL interface levels.

NOTE: *Pullup* and *Pulldown* refers to internal input resistors. See Table 2, Pin Characteristics, for typical values.

TABLE 2. PIN CHARACTERISTICS

Symbol	Parameter		Test Conditions	Minimum	Typical	Maximum	Units
C _{IN}	Input Capacitance	OE0, OE1			4		pF
C _{PD}	Power Dissipation Capacitance		V _{DD} = V _{DDO} = 3.465V			3	pF
			V _{DD} = 3.465V or 2.625V, V _{DDO} = 2.625V			4	pF
			V _{DD} = 3.465V or 2.625V, V _{DDO} = 2V			6	pF
R _{PULLUP}	Input Pullup Resistor				51		kΩ
R _{PULLDOWN}	Input Pulldown Resistor				51		kΩ
R _{OUT}	Output Impedance		V _{DDO} = 3.3V			20	Ω
			V _{DDO} = 2.5V			25	Ω
			V _{DDO} = 1.8V			38	Ω



ABSOLUTE MAXIMUM RATINGS

Supply Voltage, V_{DD}	4.6V
Inputs, V_i	-0.5V to $V_{DD} + 0.5V$
Outputs, V_o	-0.5V to $V_{DD} + 0.5V$
Package Thermal Impedance, θ_{JA}	38.5°C/W (0 mps)
Storage Temperature, T_{STG}	-65°C to 150°C

NOTE: Stresses beyond those listed under Absolute Maximum Ratings may cause permanent damage to the device. These ratings are stress specifications only. Functional operation of product at these conditions or any conditions beyond those listed in the *DC Characteristics* or *AC Characteristics* is not implied. Exposure to absolute maximum rating conditions for extended periods may affect product reliability.

TABLE 3A. POWER SUPPLY DC CHARACTERISTICS, $V_{DD} = 3.3V \pm 5\%$, $V_{DDO} = 3.3V \pm 5\% = 2.5V \pm 5\% = 1.8V \pm 0.2V$, $T_A = 0^\circ C$ TO $70^\circ C$

Symbol	Parameter	Test Conditions	Minimum	Typical	Maximum	Units
V_{DD}	Core Supply Voltage		3.135	3.3	3.465	V
V_{DDO}	Output Supply Voltage		3.135	3.3	3.465	V
			2.375	2.5	2.625	V
			1.6	1.8	2.0	V
I_{DD}	Power Supply Current				50	mA
I_{DDO}	Output Supply Current				20	mA

TABLE 3B. POWER SUPPLY DC CHARACTERISTICS, $V_{DD} = 2.5V \pm 5\%$, $V_{DDO} = 2.5V \pm 5\% = 1.8V \pm 0.2V$, $T_A = 0^\circ C$ TO $70^\circ C$

Symbol	Parameter	Test Conditions	Minimum	Typical	Maximum	Units
V_{DD}	Core Supply Voltage		2.375	2.5	2.625	V
V_{DDO}	Output Supply Voltage		2.375	2.5	2.625	V
			1.6	1.8	2.0	V
I_{DD}	Power Supply Current				50	mA
I_{DDO}	Output Supply Current				20	mA

TABLE 3C. LVCMOS/LVTTL DC CHARACTERISTICS, $T_A = 0^\circ C$ TO $85^\circ C$

Symbol	Parameter	Test Conditions	Minimum	Typical	Maximum	Units
V_{IH}	Input High Voltage	$V_{DD} = 3.3V \pm 5\%$	2		$V_{DD} + 0.3$	V
		$V_{DD} = 2.5V \pm 5\%$	1.7		$V_{DD} + 0.3$	V
V_{IL}	Input Low Voltage	OE0, OE1, DIV_SEL_Q5 $V_{DD} = 3.3V \pm 5\%$	-0.3		0.8	V
		$V_{DD} = 2.5V \pm 5\%$	-0.3		0.7	V
VC	VCXO Control Voltage		0		V_{DD}	V
I_{IH}	Input High Current	DIV_SEL_Q5 $V_{DD} = 3.3V$ or $2.5V \pm 5\%$			150	μA
		OE0, OE1 $V_{DD} = 3.3V$ or $2.5V \pm 5\%$			5	μA
I_{IL}	Input Low Current	DIV_SEL_Q5 $V_{DD} = 3.3V$ or $2.5V \pm 5\%$	-5			μA
		OE0, OE1 $V_{DD} = 3.3V$ or $2.5V \pm 5\%$	-150			μA
I_i	Input Current of VC pin	$V_{DD} = 3.465V$ or $2.625V$	-100		100	μA
V_{OH}	Output High Voltage;NOTE 1	$V_{DDO} = 3.3V \pm 5\%$	2.6			V
		$V_{DDO} = 2.5V \pm 5\%$	1.8			V
		$V_{DDO} = 1.8V \pm 0.2V$	1.5			V
V_{OL}	Output Low Voltage;NOTE 1	$V_{DDO} = 3.3V$ or $2.5V \pm 5\%$			0.5	V
		$V_{DDO} = 1.8V \pm 0.2V$			0.4	V

NOTE 1: Outputs terminated with 50Ω to $V_{DDO}/2$. See Parameter Measurement section, "Load Test Circuit" diagrams.



TABLE 4A. AC CHARACTERISTICS, $V_{DD} = V_{DDO} = 3.3V \pm 5\%$, $T_A = 0^\circ C$ TO $70^\circ C$

Symbol	Parameter	Test Conditions	Minimum	Typical	Maximum	Units
f_{OUT}	Output Frequency		12	19.44	40	MHz
$f_{jit}(\emptyset)$	RMS Phase Jitter (Random); NOTE 1	Integration Range: 1kHz- 1MHz		0.35		ps
tsk(o)	Output Skew; NOTE 2, 3	Q0:Q4			30	ps
		Q0:Q5	DIV_SEL_Q5 = $\div 1$		100	ps
t_R / t_F	Output Rise/Fall Time	20% to 80%	200		700	ps
odc	Output Duty Cycle		44		56	%

NOTE 1: Please refer to the Phase Noise Plot.

NOTE 2: Defined as skew between outputs at the same supply voltage and with equal load conditions. Measured at the output differential cross points.

NOTE 3: This parameter is defined in accordance with JEDEC Standard 65.

TABLE 4B. AC CHARACTERISTICS, $V_{DD} = 3.3V \pm 5\%$, $V_{DDO} = 2.5V \pm 5\%$, $T_A = 0^\circ C$ TO $70^\circ C$

Symbol	Parameter	Test Conditions	Minimum	Typical	Maximum	Units
f_{OUT}	Output Frequency		12	19.44	40	MHz
$f_{jit}(\emptyset)$	RMS Phase Jitter (Random); NOTE 1	Integration Range: 1kHz- 1MHz		0.38		ps
tsk(o)	Output Skew; NOTE 2, 3	Q0:Q4			20	ps
		Q0:Q5	DIV_SEL_Q5 = $\div 1$		90	ps
t_R / t_F	Output Rise/Fall Time	20% to 80%	300		800	ps
odc	Output Duty Cycle		45		55	%

NOTE 1: Please refer to the Phase Noise Plot.

NOTE 2: Defined as skew between outputs at the same supply voltage and with equal load conditions. Measured at the output differential cross points.

NOTE 3: This parameter is defined in accordance with JEDEC Standard 65.

TABLE 4C. AC CHARACTERISTICS, $V_{DD} = 3.3V \pm 5\%$, $V_{DDO} = 1.8V \pm 0.2V$, $T_A = 0^\circ C$ TO $70^\circ C$

Symbol	Parameter	Test Conditions	Minimum	Typical	Maximum	Units
f_{OUT}	Output Frequency		12	19.44	40	MHz
$f_{jit}(\emptyset)$	RMS Phase Jitter (Random); NOTE 1	Integration Range: 1kHz-1MHz		0.27		ps
tsk(o)	Output Skew; NOTE 2, 3	Q0:Q4			46	ps
		Q0:Q5	DIV_SEL_Q5 = $\div 1$		175	ps
t_R / t_F	Output Rise/Fall Time	20% to 80%	450		1400	ps
odc	Output Duty Cycle		44		56	%

NOTE 1: Please refer to the Phase Noise Plot.

NOTE 2: Defined as skew between outputs at the same supply voltage and with equal load conditions. Measured at the output differential cross points.

NOTE 3: This parameter is defined in accordance with JEDEC Standard 65.



TABLE 4D. AC CHARACTERISTICS, $V_{DD} = V_{DDO} = 2.5V \pm 5\%$, $T_A = 0^\circ C$ TO $70^\circ C$

Symbol	Parameter	Test Conditions	Minimum	Typical	Maximum	Units
f_{OUT}	Output Frequency		12	19.44	40	MHz
$f_{jit}(\emptyset)$	RMS Phase Jitter (Random); NOTE 1	Integration Range: 1kHz-1MHz		0.28		ps
tsk(o)	Output Skew; NOTE 2, 3	Q0:Q4			25	ps
		Q0:Q5	DIV_SEL_Q5 = ÷1		100	ps
t_R / t_F	Output Rise/Fall Time	20% to 80%	300		800	ps
odc	Output Duty Cycle		45		55	%

NOTE 1: Please refer to the Phase Noise Plot.

NOTE 2: Defined as skew between outputs at the same supply voltage and with equal load conditions. Measured at the output differential cross points.

NOTE 3: This parameter is defined in accordance with JEDEC Standard 65.

TABLE 4E. AC CHARACTERISTICS, $V_{DD} = 2.5V \pm 5\%$, $V_{DDO} = 1.8V \pm 0.2V$, $T_A = 0^\circ C$ TO $70^\circ C$

Symbol	Parameter	Test Conditions	Minimum	Typical	Maximum	Units
f_{OUT}	Output Frequency		12	19.44	40	MHz
$f_{jit}(\emptyset)$	RMS Phase Jitter (Random); NOTE 1	Integration Range: 1kHz-1MHz		0.26		ps
tsk(o)	Output Skew; NOTE 2, 3	Q0:Q4			40	ps
		Q0:Q5	DIV_SEL_Q5 = ÷1		175	ps
t_R / t_F	Output Rise/Fall Time	20% to 80%	450		1400	ps
odc	Output Duty Cycle		40		60	%

NOTE 1: Please refer to the Phase Noise Plot.

NOTE 2: Defined as skew between outputs at the same supply voltage and with equal load conditions. Measured at the output differential cross points.

NOTE 3: This parameter is defined in accordance with JEDEC Standard 65.



TYPICAL PHASE NOISE AT 19.44MHz @ 3.3V CORE/3.3V OUTPUT

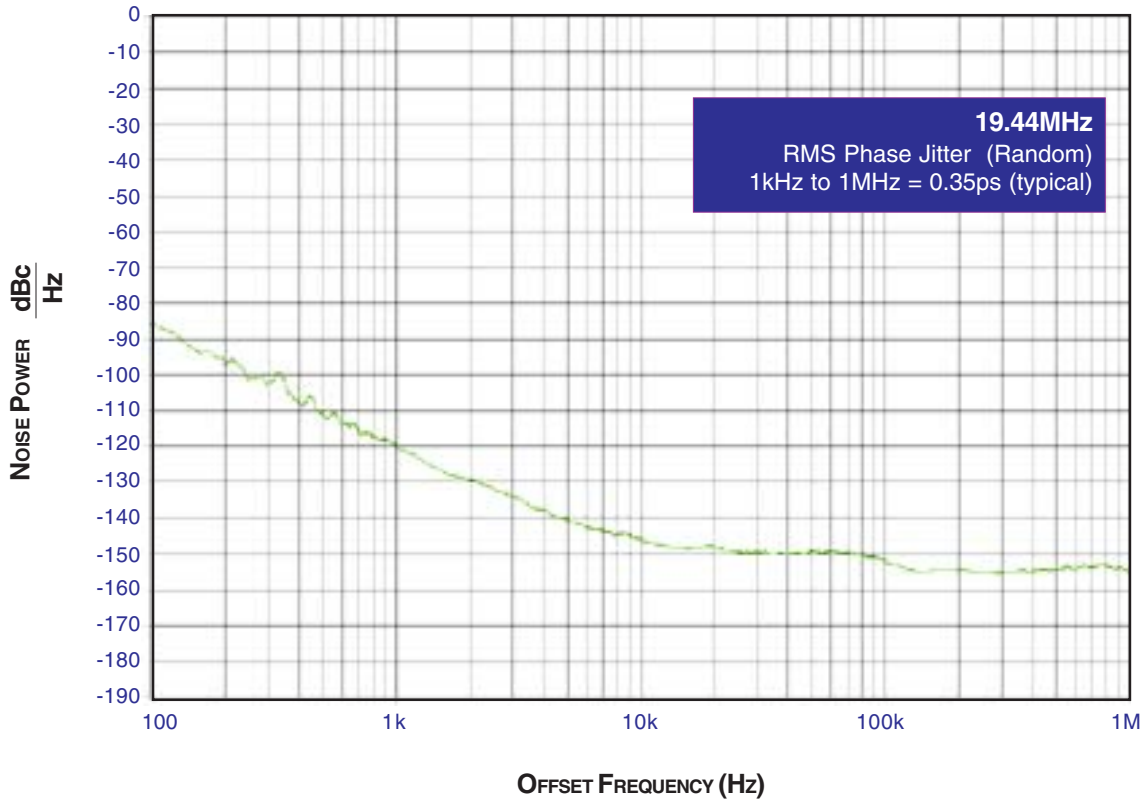



PARAMETER MEASUREMENT INFORMATION

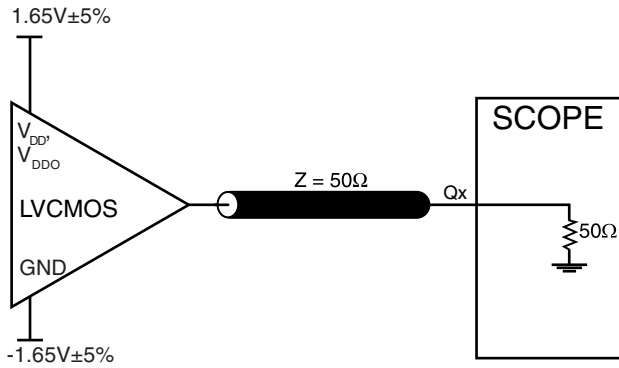

3.3V CORE/3.3V OUTPUT LOAD AC TEST CIRCUIT

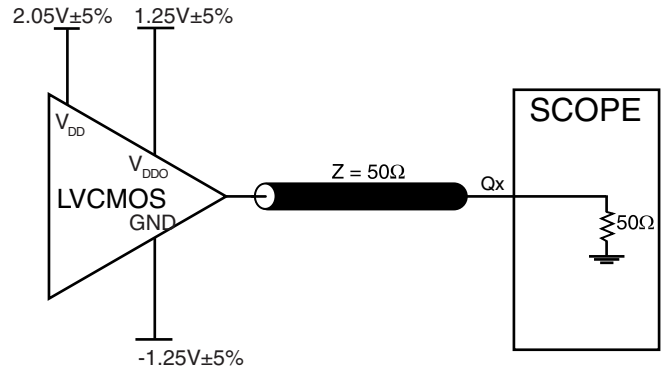

3.3V CORE/2.5V OUTPUT LOAD AC TEST CIRCUIT

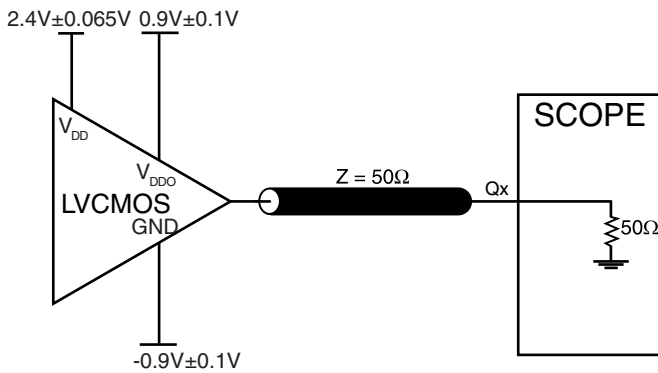

3.3V CORE/1.8V OUTPUT LOAD AC TEST CIRCUIT

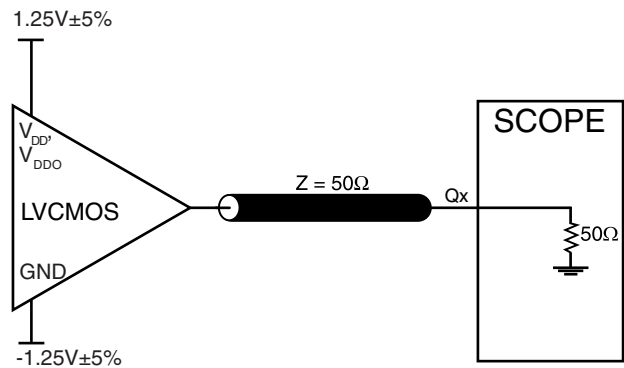

2.5V CORE/2.5V OUTPUT LOAD AC TEST CIRCUIT

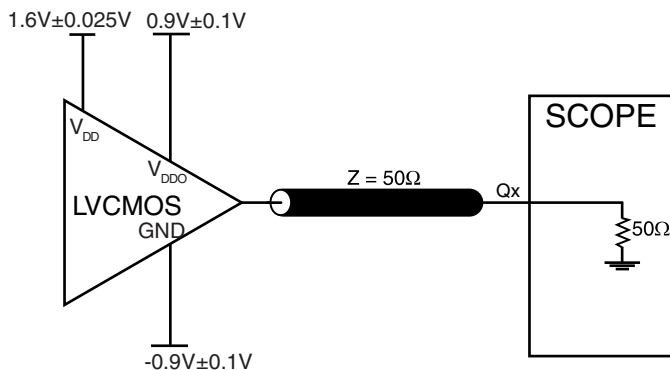

2.5 CORE/1.8V OUTPUT LOAD AC TEST CIRCUIT

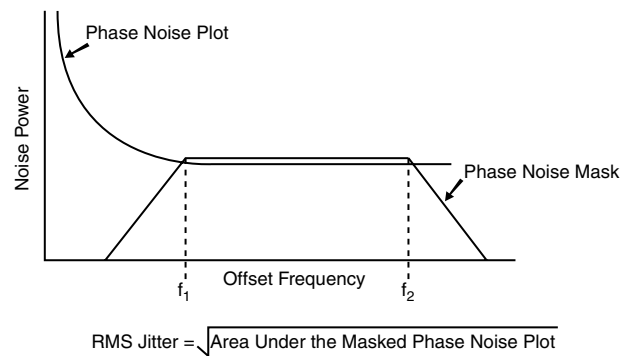

RMS PHASE JITTER

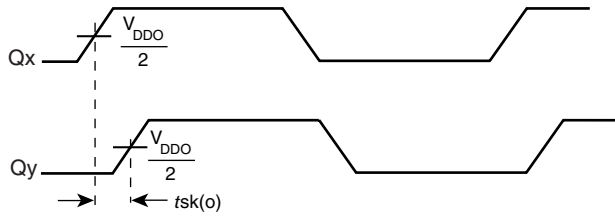

OUTPUT SKEW

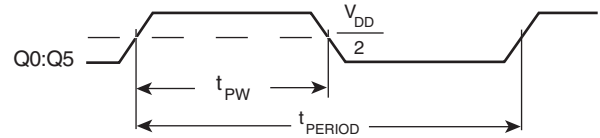

$$odc = \frac{t_{PW}}{t_{PERIOD}} \times 100\%$$

OUTPUT DUTY CYCLE/PULSE WIDTH/PERIOD

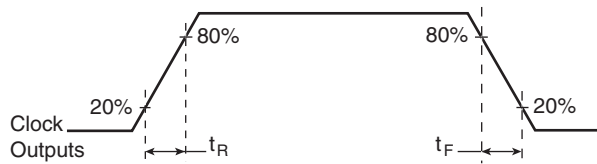

OUTPUT RISE/FALL TIME



APPLICATION INFORMATION

VCXO CRYSTAL SELECTION

Choosing a crystal with the correct characteristics is one of the most critical steps in using a Voltage Controlled Crystal Oscillator (VCXO). The crystal parameters affect the tuning

range and accuracy of a VCXO. Below are the key variables and an example of using the crystal parameters to calculate the tuning range of the VCXO.

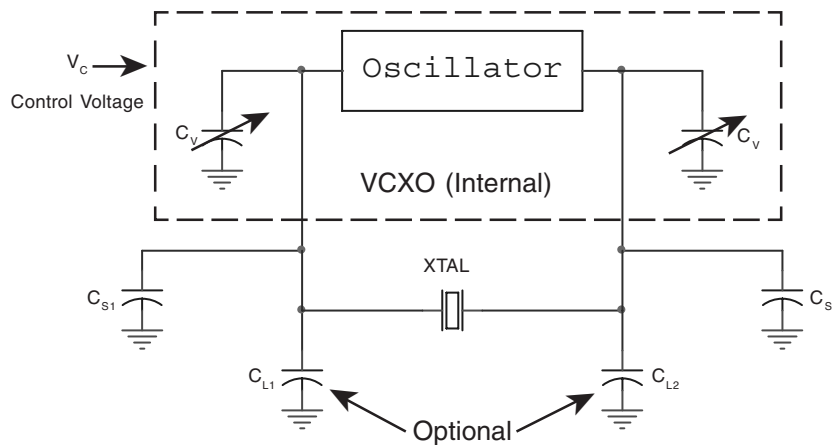

FIGURE 1: VCXO OSCILLATOR CIRCUIT

V_c Control voltage used to tune frequency

C_v Varactor capacitance, varies due to the change in control voltage

C_{L1}, C_{L2} Load tuning capacitance used for fine tuning or centering nominal frequency

C_{S1}, C_{S2} Stray Capacitance caused by pads, vias, and other board parasitics

TABLE 5. EXAMPLE CRYSTAL PARAMETERS

Symbol	Parameter	Test Conditions	Minimum	Typical	Maximum	Units
f_N	Nominal Frequency			19.44		MHz
f_T	Frequency Tolerance				±20	ppm
f_S	Frequency Stability				±20	ppm
	Operating Temperature Range		0		70	°C
C_L	Load Capacitance			12		pF
C_O	Shunt Capacitance			4		pF
C_0, C_1	Pullability Ratio			220	240	
ESR	Equivalent Series Resistance				20	
	Drive Level				1	mW
	Aging @ 25°C			±3 per year		ppm
	Mode of Operation			Fundamental		



TABLE 6. VARACTOR PARAMETERS

Symbol	Parameter	Test Conditions	Minimum	Typical	Maximum	Units
C_{V_LOW}	Low Varactor Capacitance	$V_C = 0V$		15.4		pF
C_{V_HIGH}	High Varactor Capacitance	$V_C = 3.3V$		29.6		pF

FORMULAS

$$C_{Low} = \frac{(C_{L1} + C_{S1} + C_{V_Low}) \cdot (C_{L2} + C_{S2} + C_{V_Low})}{(C_{L1} + C_{S1} + C_{V_Low}) + (C_{L2} + C_{S2} + C_{V_Low})}$$

$$C_{High} = \frac{(C_{L1} + C_{S1} + C_{V_High}) \cdot (C_{L2} + C_{S2} + C_{V_High})}{(C_{L1} + C_{S1} + C_{V_High}) + (C_{L2} + C_{S2} + C_{V_High})}$$

- C_{Low} is the effective capacitance due to the low varactor capacitance, load capacitance and stray capacitance. C_{Low} determines the high frequency component on the TPR.
- C_{High} is the effective capacitance due to the high varactor capacitance, load capacitance and stray capacitance. C_{High} determines the low frequency component on the TPR.

$$Total\ Pull\ Range\ (TPR) = \left(\frac{1}{2 \cdot C_0/C_1 \cdot \left(1 + C_{Low}/C_0\right)} - \frac{1}{2 \cdot C_0/C_1 \cdot \left(1 + C_{High}/C_0\right)} \right) \cdot 10^6$$

Absolute Pull Range (APR) = Total Pull Range – (Frequency Tolerance + Frequency Stability + Aging)

EXAMPLE CALCULATIONS

Using the tables and figures above, we can now calculate the TPR and APR of the VCXO using the example crystal parameters. For the numerical example below there were some assumptions made. First, the stray capacitance (C_{S1} , C_{S2}), which is all the excess capacitance due to board parasitic, is 4pF. Second, the expected lifetime of the project is 5 years; hence

the inaccuracy due to aging is $\pm 15ppm$. Third, though many boards will not require load tuning capacitors (C_{L1} , C_{L2}), it is recommended for long-term consistent performance of the system that two tuning capacitor pads be placed into every design. Typical values for the load tuning capacitors will range from 0 to 4pF.

$$C_{Low} = \frac{(0 + 4\ pf + 15.4\ pf) \cdot (0 + 4\ pf + 15.4\ pf)}{(0 + 4\ pf + 15.4\ pf) + (0 + 4\ pf + 15.4\ pf)} = 9.7\ pf$$

$$C_{High} = \frac{(0 + 4\ pf + 29.6\ pf) \cdot (0 + 4\ pf + 29.6\ pf)}{(0 + 4\ pf + 29.6\ pf) + (0 + 4\ pf + 29.6\ pf)} = 16.8\ pf$$

$$TPR = \left(\frac{1}{2 \cdot 220 \cdot \left(1 + \frac{9.7\ pF}{4\ pF}\right)} - \frac{1}{2 \cdot 220 \cdot \left(1 + \frac{16.8\ pF}{4\ pF}\right)} \right) \cdot 10^6 = 226.5\ ppm$$

TPR = $\pm 113.25ppm$

APR = $113.25ppm - (20ppm + 20ppm + 15ppm) = \pm 58.25ppm$

The example above will ensure a total pull range of $\pm 113.25\ ppm$ with an APR of $\pm 58.25ppm$. Many times, board designers may select their own crystal based on their application. If the application requires a tighter APR, a crystal

with better pullability (C0/C1 ratio) can be used. Also, with the equations above, one can vary the frequency tolerance, temperature stability, and aging or shunt capacitance to achieve the required pullability.



RECOMMENDATIONS FOR UNUSED INPUT AND OUTPUT PINS

INPUTS:

CONTROL PINS:

All control pins have internal pull-ups or pull-downs; additional resistance is not required but can be added for additional protection. A 1kΩ resistor can be used. The VC pin can not be floated.

OUTPUTS:

LVCMOS OUTPUT:

All unused LVCMOS output can be left floating. We recommend that there is no trace attached.

SCHEMATIC EXAMPLE

Figure 2 shows an example of ICS81006 application schematic. The decoupling capacitors should be located as close as possible to the power pin. For the LVCMOS 20Ω output

drivers, series termination example is shown in the schematic. Additional termination approaches are shown in the LVCMOS Termination Application Note.

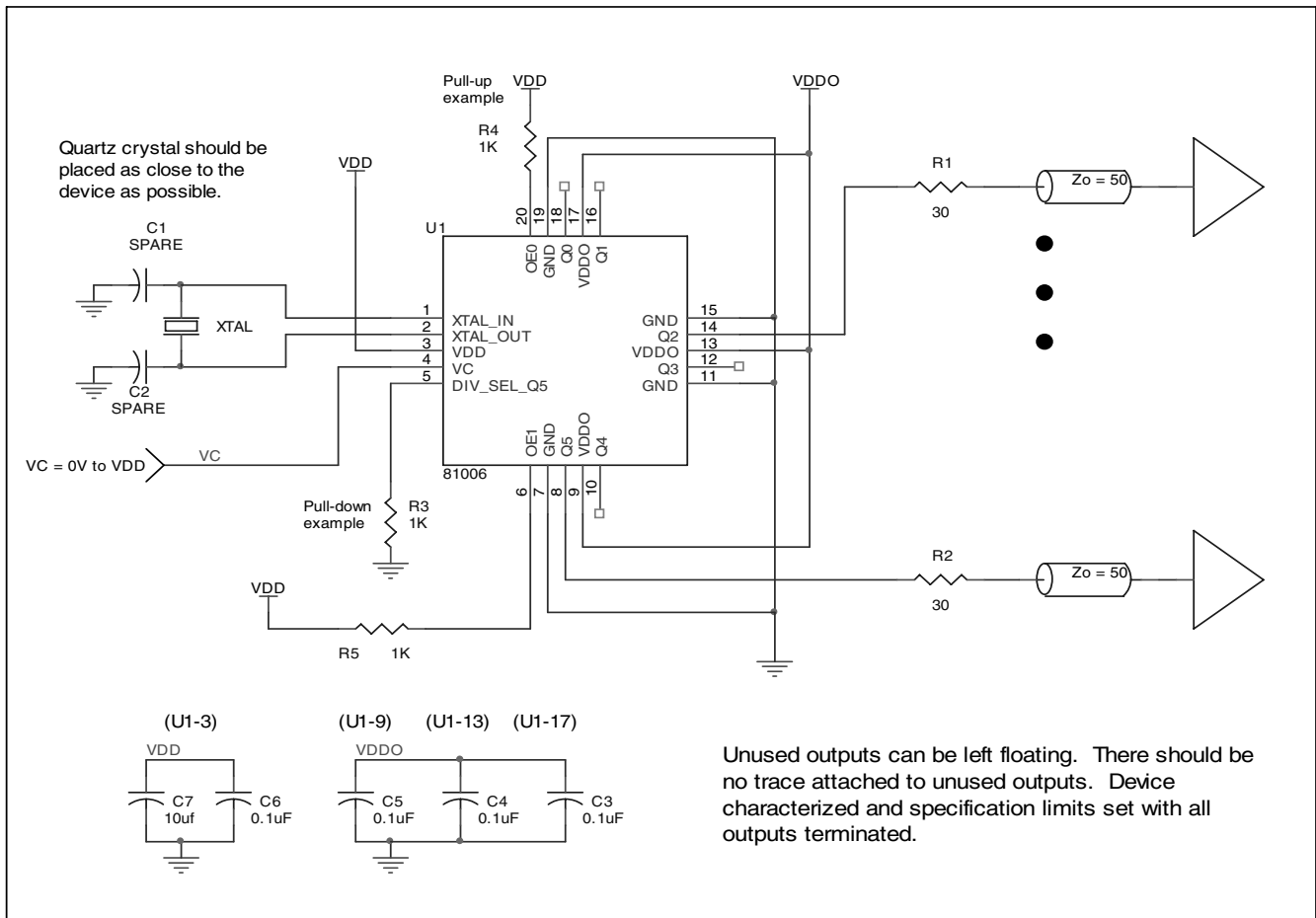

FIGURE 2. ICS81006 SCHEMATIC EXAMPLE



RELIABILITY INFORMATION

TABLE 7. θ_{JA} VS. AIR FLOW TABLE FOR 20 LEAD VFQFN

θ_{JA} by Velocity (Meters Per Second)			
	0	1	2.5
Single-Layer PCB, JEDEC Standard Test Boards	141.7°C/W	126.0°C/W	116.9°C/W
Multi-Layer PCB, JEDEC Standard Test Boards	38.5°C/W	35.0°C/W	33.4°C/W

NOTE: Most modern PCB designs use multi-layered boards. The data in the second row pertains to most designs.

TRANSISTOR COUNT

The transistor count for ICS81006 is: 983



PACKAGE OUTLINE - K SUFFIX FOR 20 LEAD VFQFN

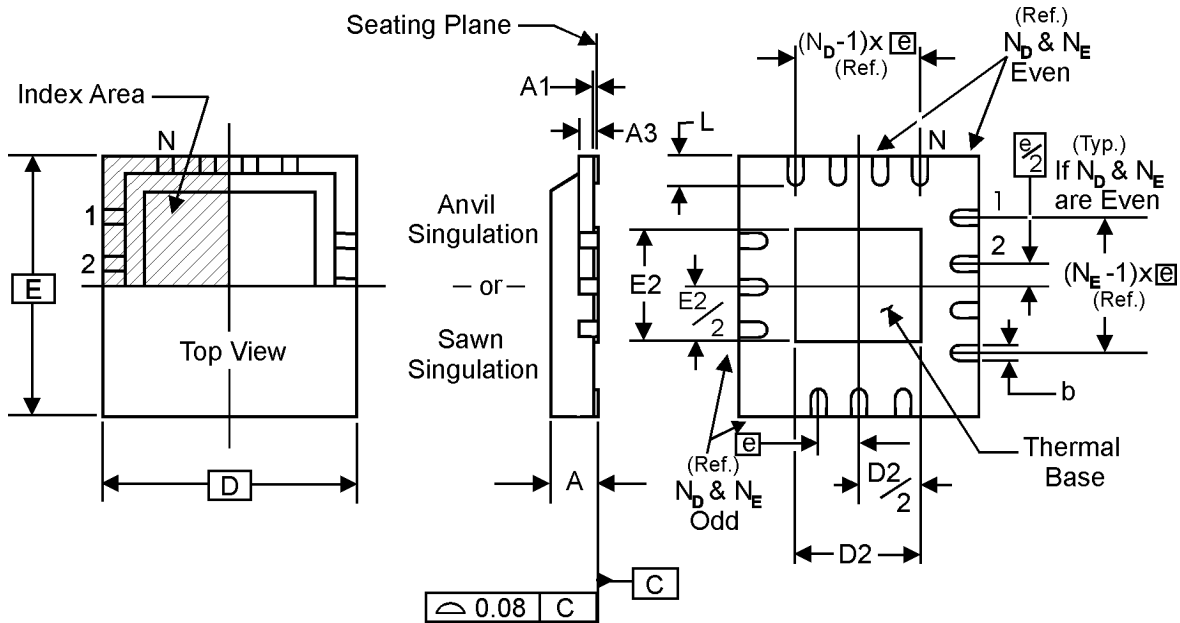

TABLE 8. PACKAGE DIMENSIONS

JEDEC VARIATION ALL DIMENSIONS IN MILLIMETERS		
SYMBOL	MINIMUM	MAXIMUM
N	20	
A	0.80	1.0
A1	0	0.05
A3	0.25 Reference	
b	0.18	0.30
e	0.50 BASIC	
N_D	5	
N_E	5	
D	4.0	
D2	0.75	2.80
E	4.0	
E2	0.75	2.80
L	0.35	0.75

Reference Document: JEDEC Publication 95, MO-220



TABLE 9. ORDERING INFORMATION

Part/Order Number	Marking	Package	Shipping Packaging	Temperature
ICS81006AK	81006A	20 lead VFQFN	tube	0°C to 70°C
ICS81006AKT	81006A	20 lead VFQFN	2500 tape & reel	0°C to 70°C
ICS81006AKLF	TBD	20 lead "Lead-Free" VFQFN	tube	0°C to 70°C
ICS81006AKLFT	TBD	20 lead "Lead-Free" VFQFN	2500 tape & reel	0°C to 70°C

NOTE: Parts that are ordered with an "LF" suffix to the part number are the Pb-Free configuration and are RoHS compliant.

The aforementioned trademark, HiPerClockS is a trademark of Integrated Circuit Systems, Inc. or its subsidiaries in the United States and/or other countries. While the information presented herein has been checked for both accuracy and reliability, Integrated Circuit Systems, Incorporated (ICS) assumes no responsibility for either its use or for infringement of any patents or other rights of third parties, which would result from its use. No other circuits, patents, or licenses are implied. This product is intended for use in normal commercial applications. Any other applications such as those requiring extended temperature range, high reliability, or other extraordinary environmental requirements are not recommended without additional processing by ICS. ICS reserves the right to change any circuitry or specifications without notice. ICS does not authorize or warrant any ICS product for use in life support devices or critical medical instruments.